

**NOTE : KINDLY FOLLOW 3D DATA FOR UNSPECIFIED DIMENSIONS.**

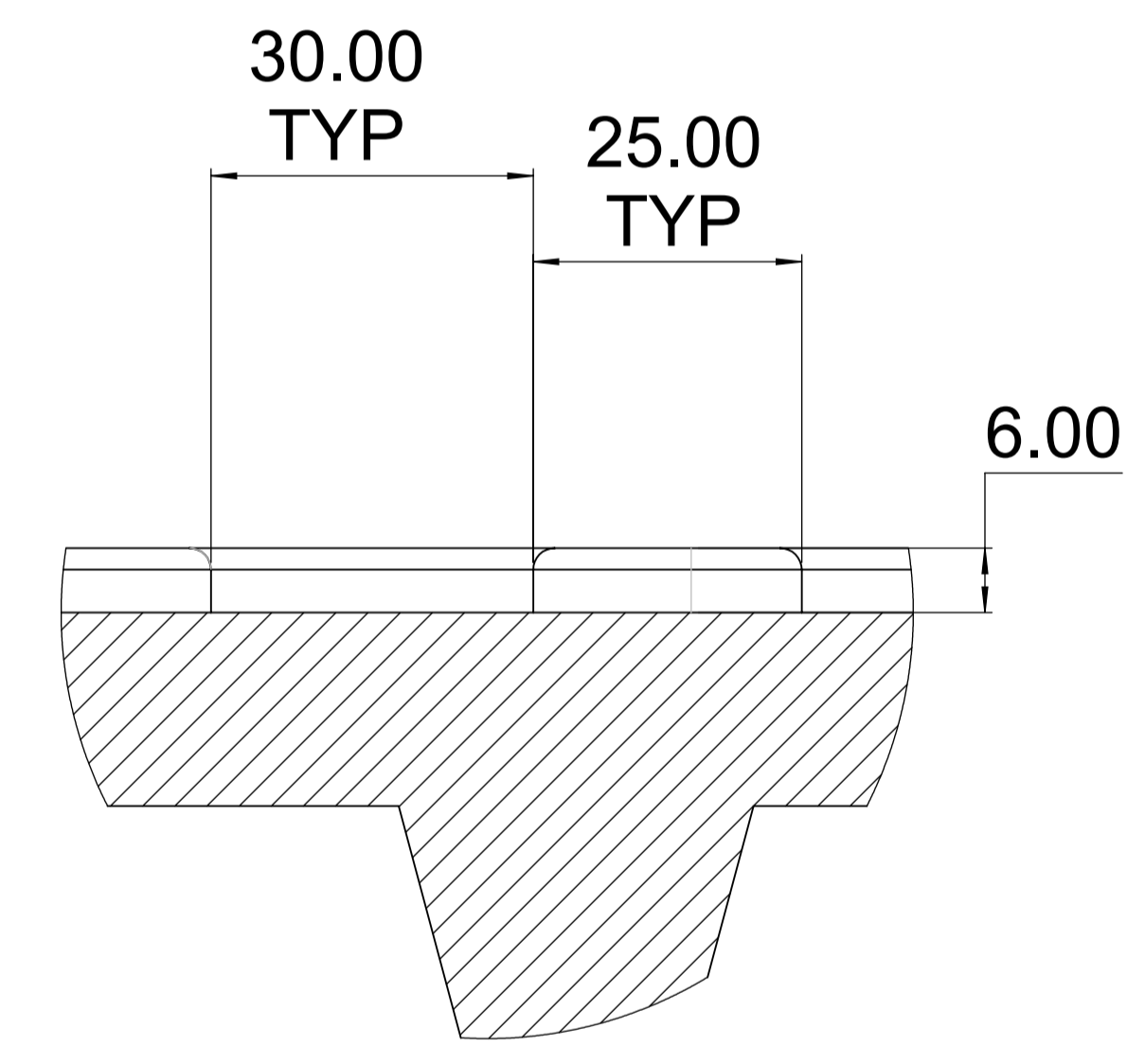

**DETAIL J  
SCALE 3 : 2**

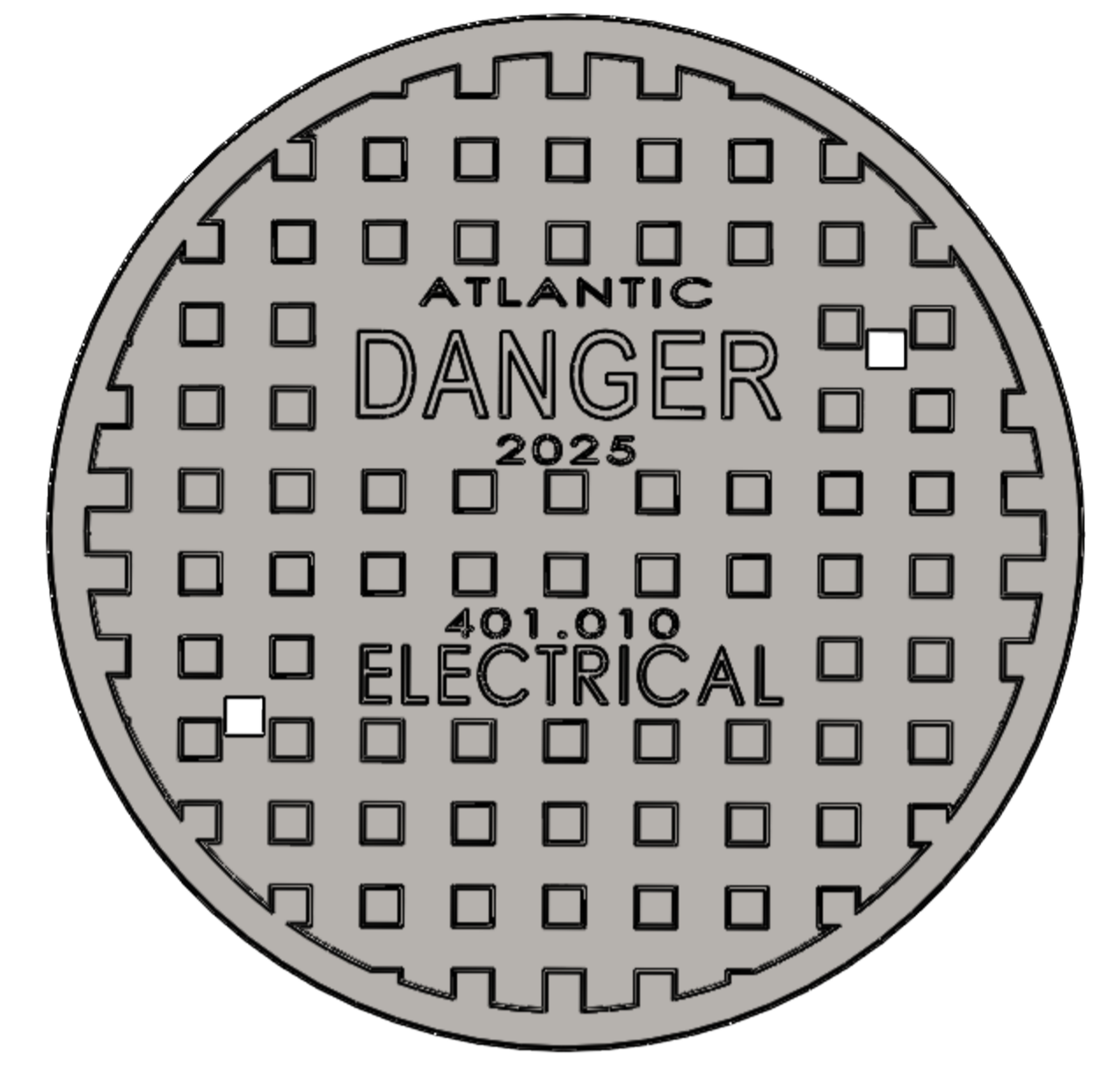
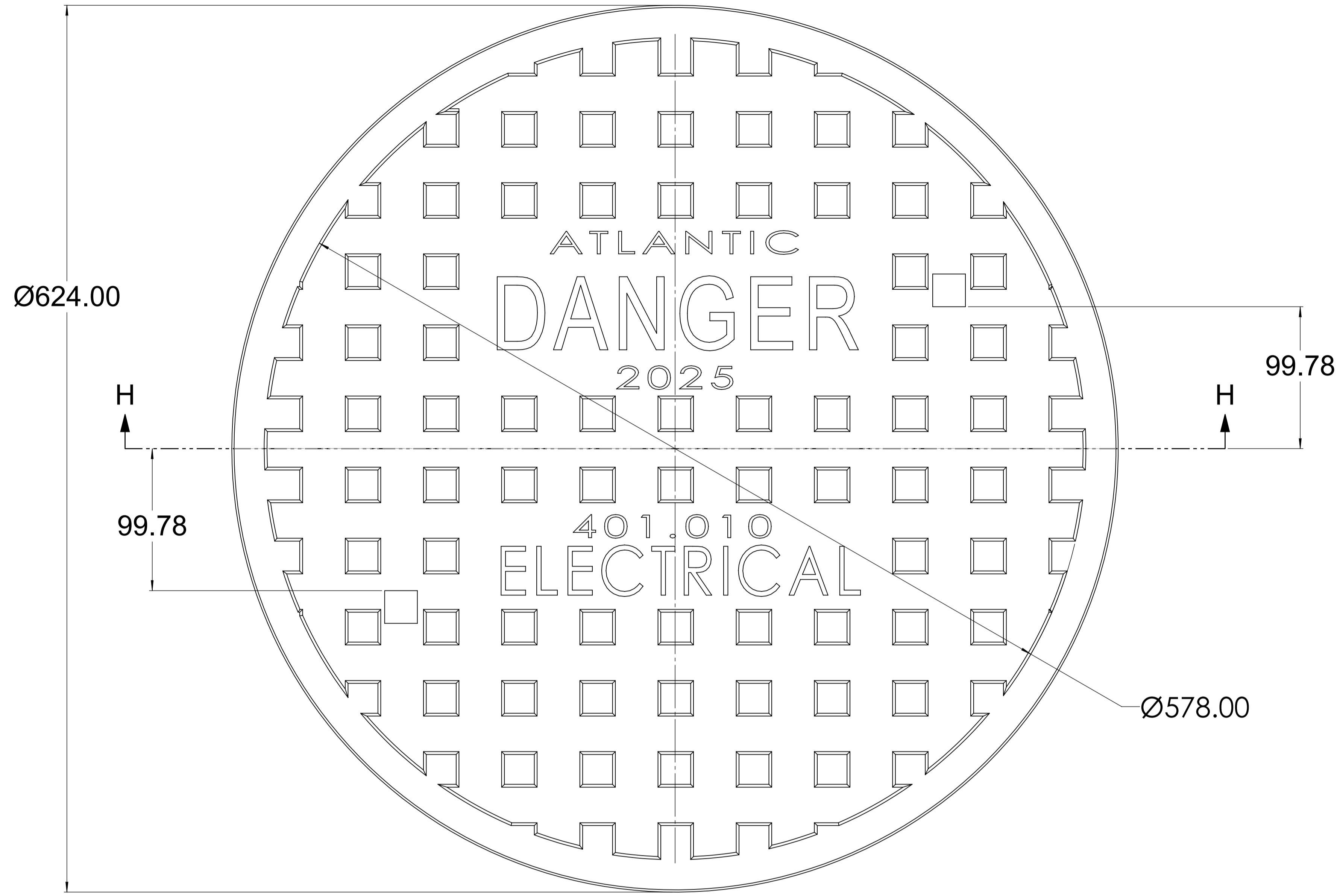
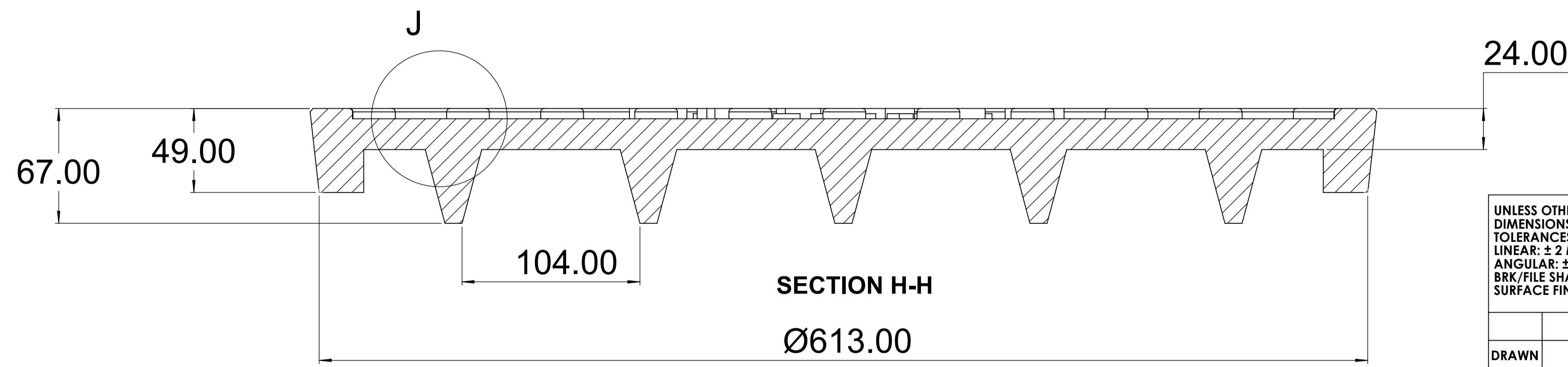

UNLESS OTHERWISE SPECIFIED:  
DIMENSIONS ARE IN MILLIMETERS  
TOLERANCES:  
LINEAR: ± 2 MM  
ANGULAR: ± 1°  
BRK/FILE SHARP CORNER: 1 MM MAX  
SURFACE FINISH: 20 - 50

THIS DRAWING IS THE PRIVATE PROPERTY OF  
"ATLANTIC CORPORATION LIMITED"  
AND CAN NOT BE USED DIRECTLY OR INDIRECTLY  
WITHOUT THE WRITTEN PERMISSION OF THE COMPANY.  
ALL LEGAL RIGHTS RESERVED.

**ATLANTIC CORPORATION  
LIMITED**

	NAME	SIGNATURE	DATE
DRAWN	ATLANTIC		28-05-2025
CHK'D			
APPV'D			
MFG	-		
Q.A			

**HEAT TREATMENT:**  
**MATERIAL:**  
ASTM-A48 CLASS-30B (CAST IRON)  
**PROJECT:**  
05  
**WEIGHT:**

**PART NAME:**  
ELECTRICAL CLOSED COVER  
**REVISION:**  
A  
**PART NUMBER:**  
401.010  
SHEET 1 OF 1  
SCALE:1:2  
SIZE: A1

**REVISIONS**

REV.	DATE	DESCRIPTION	EARLIER WAS	CHANGED TO
A	28-05-2025	DRAWING RELEASED	INITIAL RELEASE	INITIAL RELEASE