

**NOTE : KINDLY FOLLOW 3D DATA FOR UNSPECIFIED DIMENSIONS.**

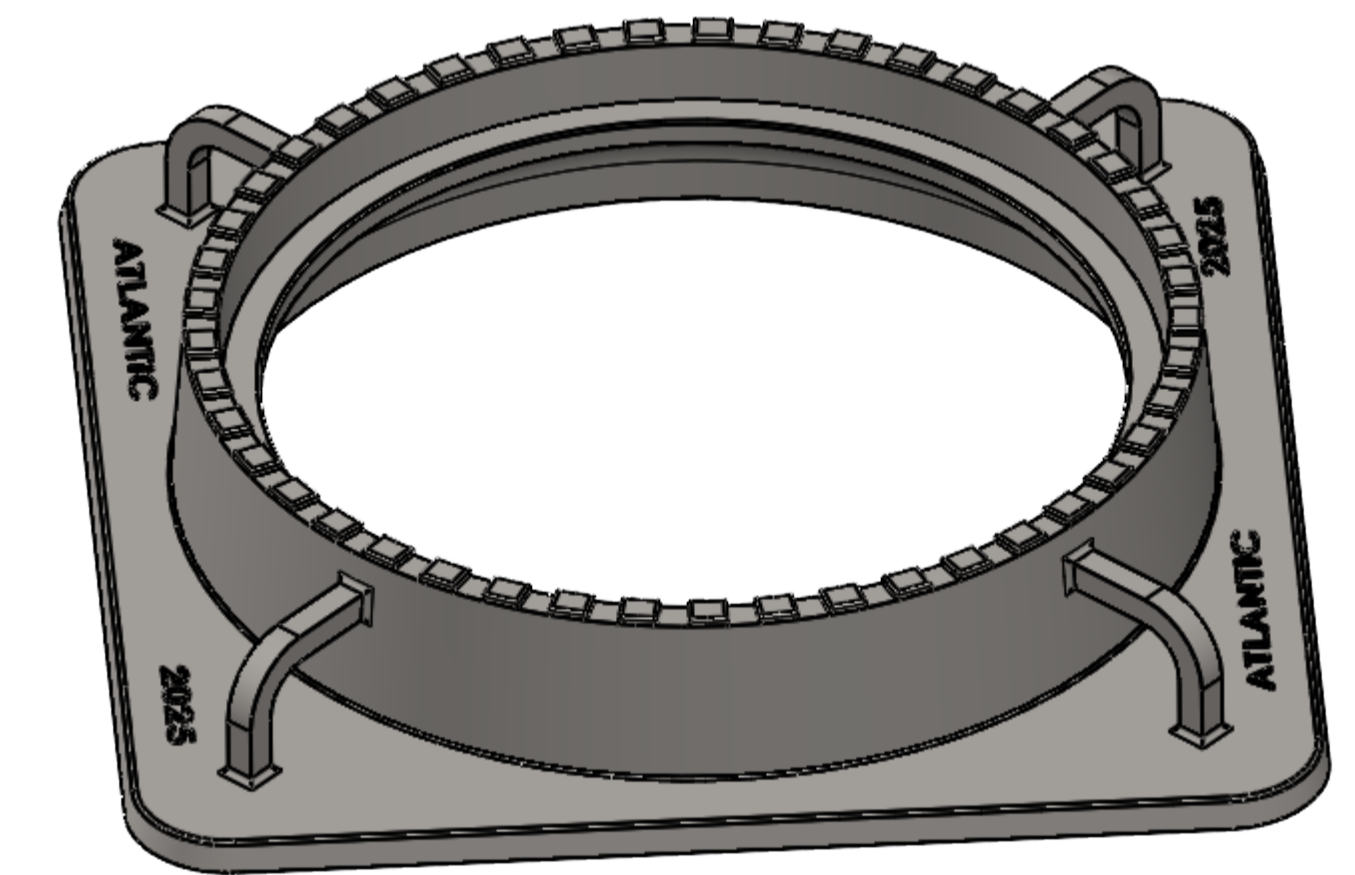
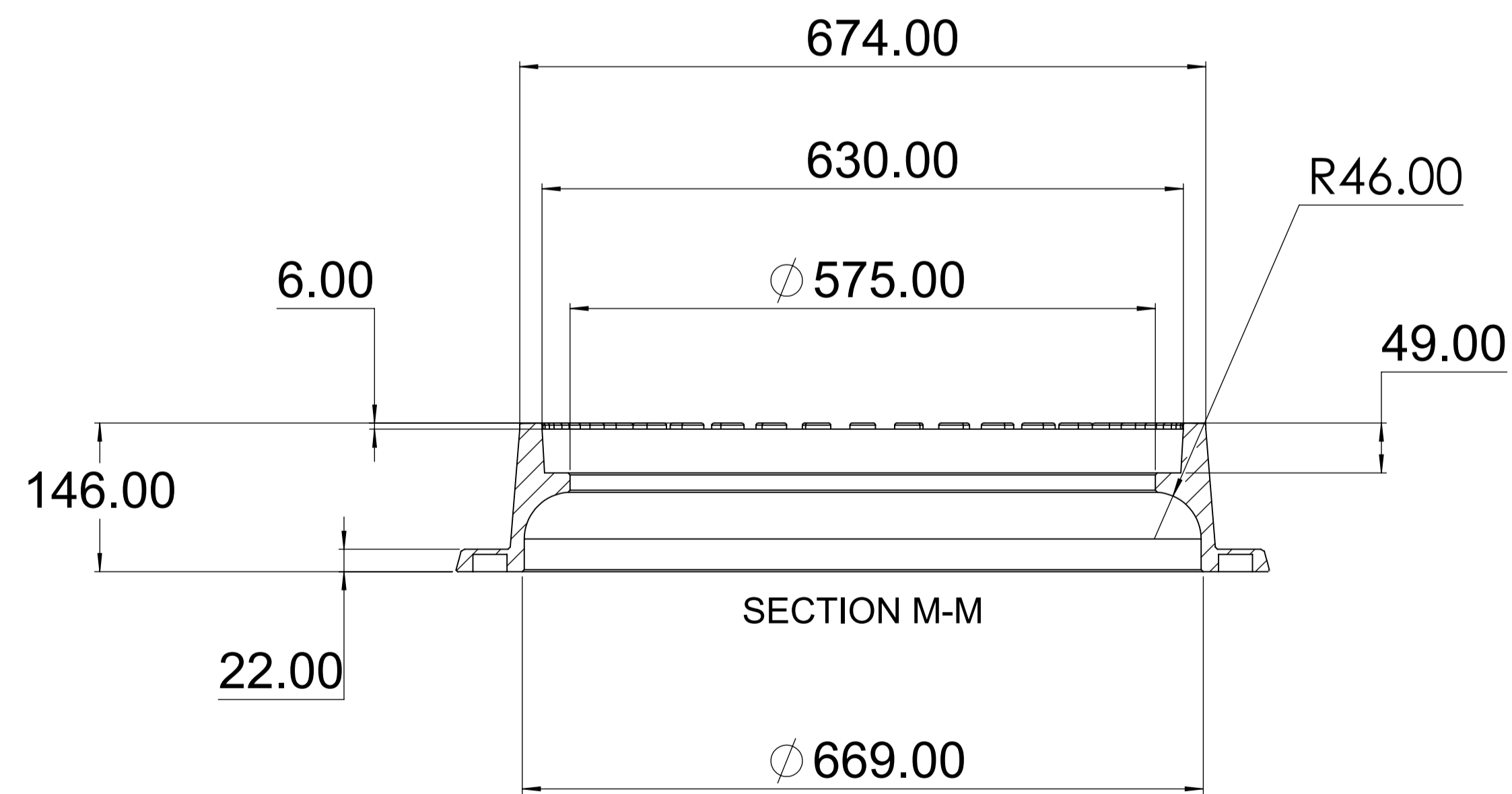
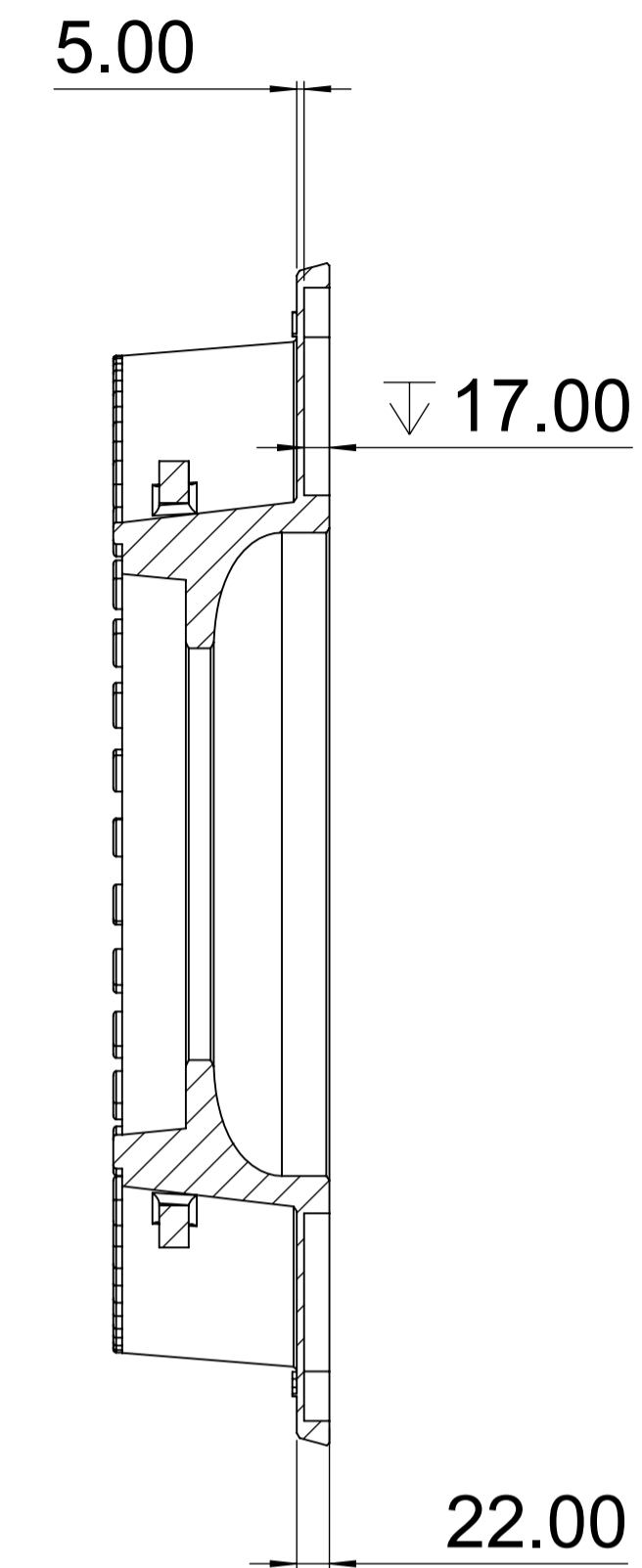
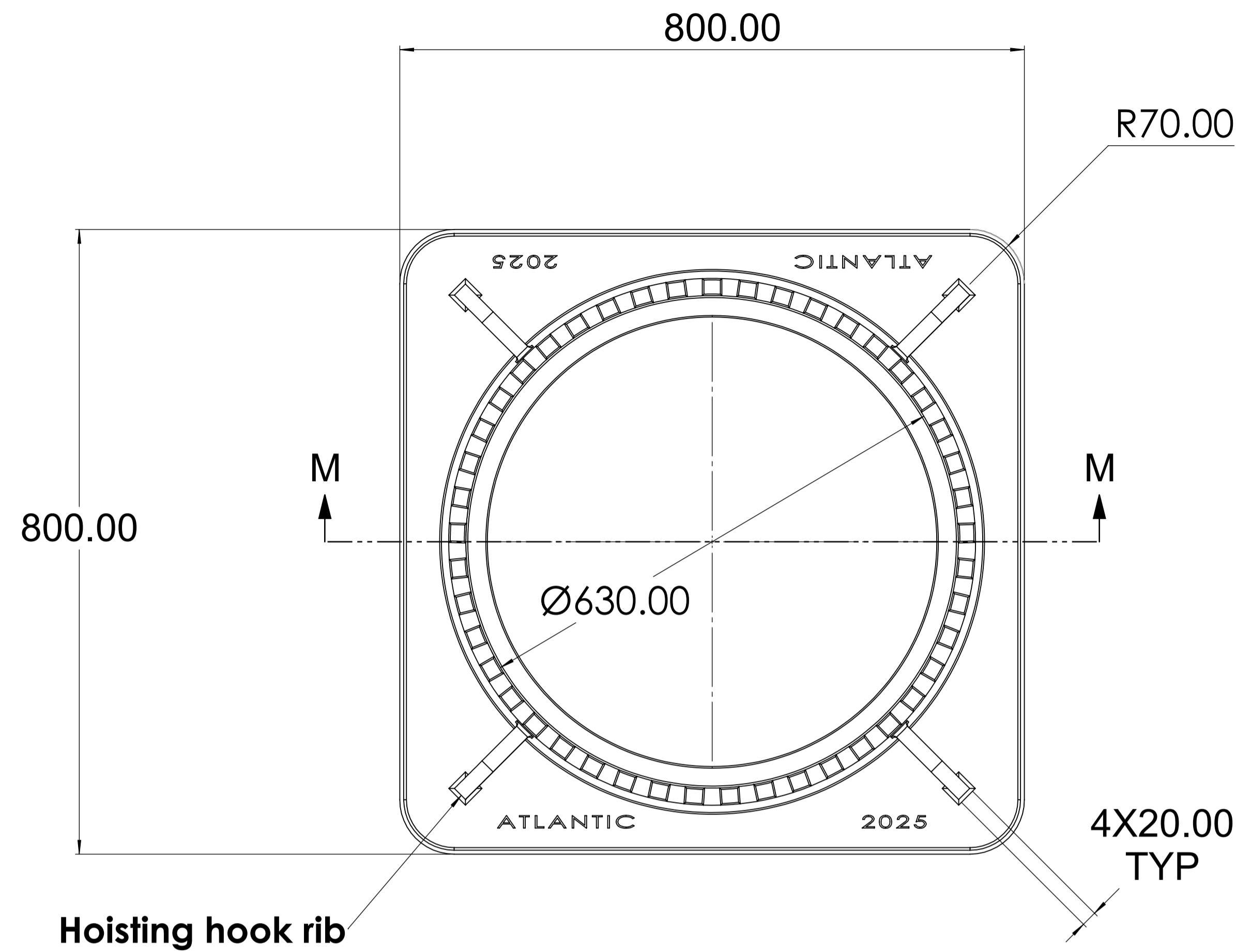

|  |            |                  |                 |   |  |   |  |
|--|------------|------------------|-----------------|---|--|---|--|
| UNLESS OTHERWISE SPECIFIED:<br>DIMENSIONS ARE IN MILLIMETERS<br>TOLERANCES:<br>LINEAR: ± 2 MM<br>ANGULAR: ± 1°<br>BRK/FILE SHARP CORNER: 1 MM MAX<br>SURFACE FINISH: 20 - 50 |            |                  |                 | THIS DRAWING IS THE PRIVATE PROPERTY OF<br>"ATLANTIC CORPORATION LIMITED"<br>AND CAN NOT BE USED DIRECTLY OR INDIRECTLY<br>WITHOUT THE WRITTEN PERMISSION OF THE COMPANY.<br>ALL LEGAL RIGHTS RESERVED. |  | <b>ATLANTIC CORPORATION<br/>LIMITED</b>     |  |
| DRAWN: ATLANTIC  |            | SIGNATURE:       |                 | DATE: 28-05-2025  |  | HEAT TREATMENT:                             |  |
| CHK'D:   |            | SIGNATURE:       |                 | DATE:   |  | MATERIAL:<br>ASTM-A48 CLASS-30B (CAST IRON) |  |
| APPV'D:  |            | SIGNATURE:       |                 | DATE:   |  | PROJECT:<br>05                              |  |
| MFG:   |            | SIGNATURE:       |                 | DATE:   |  | PART NAME:<br>ELECTRICAL FRAME              |  |
| Q.A:   |            | SIGNATURE:       |                 | DATE:   |  | PART NUMBER:<br>401.010                     |  |
| <b>REVISIONS</b>   |            |                  |                 | DO NOT SCALE DRAWING  |  | WEIGHT:                                     |  |
| REV.   | DATE       | DESCRIPTION      | EARLIER WAS     | CHANGED TO  |  | SHEET 1 OF 1                                |  |
| A  | 28-05-2025 | DRAWING RELEASED | INITIAL RELEASE | INITIAL RELEASE   |  | SCALE: 1:5                                  |  |
|  |            |                  |                 |   |  | SIZE: A1                                    |  |